

1 **EU-TYPE EXAMINATION CERTIFICATE**

2 Equipment intended for use in Potentially Explosive Atmospheres Directive 2014/34/EU

3 Certificate Number: **CSANe 24ATEX1052X** Issue: **0**

4 Equipment: **Igniter Coils; Type SA91 and Type SA101**

5 Applicant: **Igniters Combustion Engineering Limited**

6 Address: Unit 6 Prospect Drive
Enterprise Industrial Estate
Lichfield
Staffs
WS14 9UX
England

7 This equipment and any acceptable variation thereto is specified in the schedule to this certificate and the documents therein referred to.

8 CSA Group Netherlands B.V., notified body number 2813 in accordance with Articles 17 and 21 of Directive 2014/34/EU of the European Parliament and of the Council, dated 26 February 2014, certifies that this equipment has been found to comply with the Essential Health and Safety Requirements relating to the design and construction of equipment intended for use in potentially explosive atmospheres given in Annex II to the Directive.

The examination and test results are recorded in the confidential reports listed in Section 14.2.

9 Compliance with the Essential Health and Safety Requirements, with the exception of those listed in the schedule to this certificate, has been assured by compliance with the following documents:

EN IEC 60079-0:2018 incl. AC:2020-02 EN 60079-18:2015 incl. AC:2018
EN 60079-7:2015 + Amd1:2017

10 If the sign 'X' is placed after the certificate number, it indicates that the equipment is subject to Specific Conditions of Use identified in the schedule to this certificate.

11 This EU-Type Examination Certificate relates only to the design and construction of the specified equipment. If applicable, further requirements of this Directive apply to the manufacture and supply of this equipment.

12 The marking of the equipment shall include the following:



II 2G

Ex eb mb IIC T6 Gb

The ambient temperature ranges aren't shown on the label, it is covered in the Specific Conditions of Use.

Signed: M Halliwell

Title: Director of Operations



Project Number 80106201

This certificate and its schedules may only be reproduced in its entirety and without change
CSA Group Netherlands B.V. Utrechtseweg 310, Building B42, 6812AR Arnhem, The Netherlands



SCHEDULE

EU-TYPE EXAMINATION CERTIFICATE

CSANe 24ATEX1052X
Issue 0

13 DESCRIPTION OF EQUIPMENT

The Type SA101 and SA91 Ignition Coils consist of an encapsulated coil assembly fitted within a cylindrical steel body. The steel body has two threaded steel end caps, one of which is centrally threaded to accept a cable gland with a supply cable, the other end cap is either similarly threaded or has a raised threaded centre section. End caps are secured in place with either thread sealant or encapsulant during assembly.

The cable gland may be a Hawke Type 501/453 that is certified by CML, certificate no. CML 18 ATEX1268X, to the latest standards and coded Ex db IIC/Ex eb IIC. Alternatively, any Ex db IIC or Ex eb IIC ATEX approved cable gland (to the latest standards) may be used provided it is suitable for the cable i.e. it clamps the cable screen securely.

The supply cable may be either SY (PVC/PVC/GSAB/PVC), SWA or Silicone (Steel over braid) or HOFR (Heat and Oil Resistant, Flame-Retardant), or RFOU (R [Ethylene Propylene rubber] F [Flame Retardant, halogen free – bedding] O [tinned copper wire braid – armour] U [Flame retardant, halogen free – outer sheath]). It has 3 cores with a conductor size between 0.75 mm² and 1.5 mm². The integral earth conductor is connected directly to an earthing terminal on the inside face of the end cap and the armour or braid is earthed to the cable gland.

It is intended that the primary winding of the coil shall be supplied from a pulsed DC low voltage supply that has a nominal peak voltage of 175 V. The secondary winding, which is connected directly to the primary winding, produces a similar pulsed output at a peak voltage of 8000V or 8750V for the Type SA91 and 8000V for the Type SA101.

The secondary winding output terminal is made by use of an insulated threaded stud fitted into the end of the coil assembly. This connection either extends out of the whole assembly onto a spark ignition device fitted in the combustion chamber of the associated fuel-burning apparatus (Type SA91) or is fitted into a quick release screwed connector (Type SA101). Either the quick release connector or the screw thread of the end cap is used to safely mount the ignition coil directly onto the fuel-burning apparatus.

The coil must be supplied through a pulsing circuit, which provides the specified input signal. This is limited by a 500-mA output fuse.

14 DESCRIPTIVE DOCUMENTS

14.1 Drawings

Refer to Certificate Annexe.

14.2 Associated Reports and Certificate History

Issue	Date	Report number	Comment
0	06 March 2024	R80106201A	The release of the prime certificate.

15 SPECIFIC CONDITIONS OF USE (denoted by X after the certificate number)

- 15.1 The electrical input to the coil shall only be supplied by a pulsing unit, as specified by the manufacturer, that produces a pulsed DC low voltage supply that has a nominal peak voltage of 175V at a limiting current of 250-mA (protected by a 500-mA fuse). The 500-mA fuse shall have at least a 1500A breaking capacity.

Project Number 80106201

This certificate and its schedules may only be reproduced in its entirety and without change
CSA Group Netherlands B.V. Utrechtseweg 310, Building B42, 6812AR Arnhem, The Netherlands



SCHEDULE

EU-TYPE EXAMINATION CERTIFICATE

**CSANe 24ATEX1052X
Issue 0**

- 15.2 The pulsing unit shall either be situated in a non-hazardous area or, if it is in a hazardous area, it shall be protected by a suitably approved ATEX enclosure.
- 15.3 The supply lead shall either be terminated in a non-hazardous area or, if it is connected in a hazardous area, it shall be suitably terminated and protected in accordance with EN IEC 60079-0:2018 incl. AC:2020-02 and EN 60079-18:2015 incl. AC:2018.
- 15.4 The quick release connector shall not be connected or disconnected whilst it is energised in a hazardous area.
- 15.5 The coil shall not be energised if the quick release connector is separated.
- 15.6 The minimum cable bending radii are listed below:

Cable Type	Minimum Bend Radius
SY (PVC/PVC/GSWB/PVC)	20 x Diameter
SWA	6 x Diameter
Silicone (Steel Overbraid)	20 x Diameter
HOFR	8 x diameter
RFOU	8 x diameter

The cable shall not be subjected to bends that are more onerous than those values listed.

- 15.7 The ambient temperature ranges applicable to the SA9* Ignition Coil are listed below:

Cable Type	Installation Type	
	Flexible (°C)	Fixed (°C)
SY (PVC/PVC/GSWB/PVC)	-5 to +70	-40 to +70
SWA	N/A to +70	-40 to +70
Silicone (Steel Overbraid)	-25 to +70	-60 to +70
HOFR	-20 to +70	-20 to +70
RFOU	-20 to +70	-50 to +70

The SA9* Ignition Coil shall only be used within these temperature ranges.

- 15.8 The quick release connector must only be connected to the mating parts fitted to the fuel-burning apparatus.
- 15.9 When the SA9* Ignition Coil with a Steel Wire is being installed with Armoured supply cable, it shall not be subjected to temperatures below 0°C.
- 15.10 The equipment shall be located where it is not subject to water contamination.
- 16 **ESSENTIAL HEALTH AND SAFETY REQUIREMENTS OF ANNEX II (EHSRs)**
The relevant EHSRs that are not addressed by the standards listed in this certificate have been identified and individually assessed in the reports listed in Section 14.2.
- 17 **CONDITIONS OF MANUFACTURE**
- 17.1 The use of this certificate is subject to the Regulations Applicable to Holders of CSA Group Netherlands B.V. certificates.

Project Number 80106201

This certificate and its schedules may only be reproduced in its entirety and without change
CSA Group Netherlands B.V. Utrechtseweg 310, Building B42, 6812AR Arnhem, The Netherlands



SCHEDULE

EU-TYPE EXAMINATION CERTIFICATE

**CSANe 24ATEX1052X
Issue 0**

- 17.2 Holders of EU-Type Examination Certificates are required to comply with the conformity to type requirements defined in Article 13 of Directive 2014/34/EU.
- 17.3 The encapsulated parts of the apparatus shall be subjected to a visual inspection. No visible damage of the compound shall be evident, such as cracks, exposure of the encapsulated parts, flaking, impermissible shrinkage, discoloration, swelling, decomposition or softening, as required by EN 60079-18:2015 incl. AC:2018, clause 9.1.
- 17.4 An electric strength test of 2U + 1000 V (where U is the supply voltage) with a minimum of 1500 Vac, shall be applied between circuit and casing for at least 1 minute as required by clause 9.2 of EN 60079-18:2015 incl. AC:2018. No breakdown shall occur.
- 17.5 The electrical data shall be checked by measurement of voltage, current and active power, as required by clause 4.4 of EN 60079-18:2015 incl. AC:2018. Alternatively, the following functional test may be carried out in lieu.

The functional test requires connection to a suitable control unit and spark gap. Operate control unit and check for a continuous spark across the spark gap. When spark stops (after 5 seconds approx.), fit a diode-probe across the spark-gap to simulate flame and check flame signal on control unit.

- 17.6 This certificate relies on the following previously certified product, to the latest standards. When used as part of the Type SA9* Ignition Coil, the key attributes listed in the table below shall still be maintained by their original certificate.

Description	Certificate No.	Key attributes
Hawke, Type 501/453	CML 18ATEX1268X	Ex db IIC Gb or Ex eb IIC Gb
Any suitable ATEX approved gland	As appropriate	Ex db IIC Gb or Ex eb IIC Gb

- 17.7 The manufacturer shall clearly identify the type of supply cable that is used in the SA9* Ignition Coil so that the user/installer can comply with the specific conditions of use that are applicable to that cable.

Certificate Annexe



Certificate Number: CSANe 24ATEX1052X

Equipment: Igniter Coils; Type SA91 and Type SA101

Applicant: Igniters Combustion Engineering Limited

Issue 0

Drawing	Sheets	Rev.	Date (Stamp)	Title
A4/1G/13798B	1 of 1	B	19 Feb 24	SA101, SA91 label
A2/1G/13762A	1 of 1	A	16 Feb 24	SA101 Encapsulated Coil, assembly
A2/1G/9443L	1 of 1	L	16 Feb 24	SA91 Encapsulated Coil Screw In, assembly

Project Number 80106201

This certificate and its schedules may only be reproduced in its entirety and without change
CSA Group Netherlands B.V. Utrechtseweg 310, Building B42, 6812AR Arnhem, The Netherlands



EU Declaration of Conformity

Page 1 of 1
Revision 1.7
25.10.2023

This Declaration of Conformity is issued under the sole responsibility of Igniters Combustion Engineering Ltd., the manufacturer.

Ignition systems manufactured by Igniters Combustion Engineering Ltd. comply with the applicable requirements of:

- Machinery Directive 2006/42/EU,
- Low Voltage Directive 2014/35/EU, and
- EMC Directive 2014/30/EU.

The following standards have been referenced:

- BS EN 746-1:1997+A1:2009, and
- BS EN 746-2:2022

The CU7/3B and CU7/4B Control Units have been tested by:

BSI
Holywell Park
Ashby Road
Loughborough
LE11 3AQ
Notified Body No. 0086

for compliance with the applicable clauses of EN 298:2022, as described in report 3914089.dated 07.08.2023.

Pressure Equipment Directive 2014/68/EU

Ignition systems manufactured by Igniters Combustion Engineering Ltd. have been designed to Sound Engineering Practice and are therefore not CE marked for compliance with the Pressure Equipment Directive 2014/68/EU.

ATEX Directive 2014/34/EU

Igniters Combustion Engineering Ltd. declare that the products listed below conform with the relevant provisions of Directive 2014/34/EU of 26th February 2014.

Products

- Encapsulated coils type SA9* and pilot torch connections
- HT Ignition Lead type SA87 and pilot torch connections

Notified Body

CSA Group Netherlands B.V.
Utrechtseweg 310,
6812 AR, Arnhem,
Netherlands

Identification Number: 2813

Conformity has been demonstrated with reference to the following documentation:

- EC type examination certificate Sira 02ATEX5301X.
- EC type examination certificate Sira 02ATEX3390X.
- Quality Assurance Notification Sira 02ATEXM197.

Compliance with the Essential Health and Safety Requirements has been assessed by reference to the following standards:

- EN 1127-1:2019.

Richard English,
Managing Director
Lichfield, England

Unit 6 Prospect Drive
Enterprise Industrial Estate
Lichfield
Staffordshire
WS14 9UX
Tel: 01543 251478
Fax: 01543 257850
Email: info@igniters.co.uk
Website: www.igniters.co.uk

IGNITERS
COMBUSTION
ENGINEERING
LIMITED

Internal Circuit

Figure 1 Coil internal circuit.

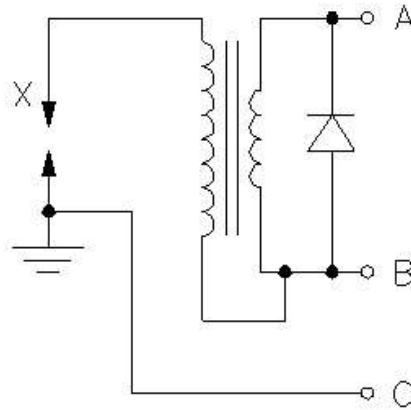

Table 1 Core Identification Cross Reference

	Encapsulated Coil Terminations (see Figure 1)		
	A	B	C
Core Identification	Brown	Blue	Green /Yellow
	Brown	White	Green
	Red	Blue	Yellow
	1	2	3
	Brown	Grey	Black